

LUMENE 

THE ULTIMATE WIDE SCREEN EXPERIENCE

HOME THEATER SCREENS



SCREEN'S BEST QUALITY

Those who visited Le Grand Rex (Paris - France) or the Fox Arlington main auditorium (Santa Barbara - USA) may remember the star filled sky, the heavy velvet curtain, the huge wide screen and all the other luxury accessories that turned every single projection into an unforgettable and unique experience. The quality level of those legendary theaters was unlimited: In 1929, the San Francisco Fox theater curtain was estimated at US \$8,900.00, made of silk with gold inserts and 2500 mirrors! At this time, famous theaters such as Movie Palace, Majestic or Coliseum, were so much more than simple projection area. To go to this kind of mythic places, with their sumptuous decor, was always a testimony of pleasure, good time, and magic. Lumene focus is to let the magic enter your home! High-quality video-projectors are now available for competitive prices. The projection surface remains anyhow a crucial factor for picture quality.

Lumene is constantly improving its products for even simpler installation and impeccable image quality. Lumene screens are manufactured with a high quality projection fabric, made in the USA. All our screens feature black borders as well as dust free treatment. The screen material has been developed to enhance picture quality by magnifying contrast and by ensuring vivid and true-to-life colors. Dedicated to home theater use, our screens are designed to make sure that you always get the best of your DLP or LCD projector. The case design, light and elegant, will easily blend into any room, without disfiguring your decor. The wall or ceiling mounting system allows flexible and convenient home integration. SOMFY motors power the motorized screens for an everlasting quiet operation. In our "picture-oriented" world, it is now possible to let the wide screen experience enter your home. With Lumene screens, you can afford a high-quality projection screen for the best price for value.



LUMENE SCREEN RANGE

SPECIFICATIONS

SCREEN TYPE

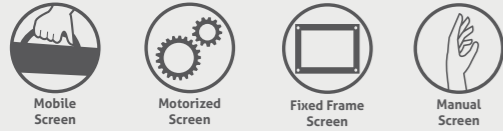

SCREEN OPENING

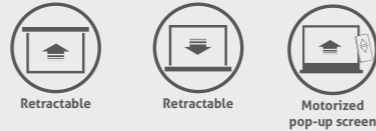

SCREEN FINISH



SCREEN CONTROL



ADVANCED FEATURES

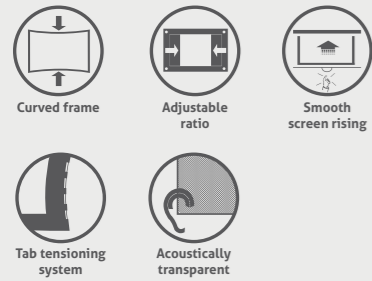

MOUNTING FEATURES



COMPARATIVE TABLE

Features		Capitol Premium	Majestic Premium	ShowPlace Premium	Coliseum Premium	Eden	Piazza 2	Embassy 2	Paradise	Arcadia	Movie Palace Premium	Movie Palace Premium Acoustic	Movie Palace Premium Curve	Movie Palace Premium Multi	TableShow	
Aspect Ratio	1:1 (Square)															
	4:3 (Video)	•	•				•	•	•	•				•		•
	16:9 (Cinéma)	•	•	•	•	•	•	•	•	•	•	•	•	•		
	1:2.35 (CinémaScope)													•		
Type	Manual	•					•		•	•						•
	Motorized		•	•	•	•		•								
Frame	Tubular					•					•	•	•	•		
	Synchronous							•								
Motor	SQMFY		•	•	•											
	Floor					•			•	•						
	Table															•
	Wall	•	•		•		•	•			•	•	•	•		
Installation	Ceiling	•	•	InCeiling	•		•	•								
	Suspended	•	•		•		•	•								
	Portable					•			•	•						•
Tailor-made ratio and sizes																
Size (basis)	65 cm															•
	80 cm															•
	130 cm								•							•
	150 cm					•	•			•						•
	170 cm						•	•	•	•	•				•	•
	180 cm					•										
	200 cm	•	•	•	•		•	•		•	•	•	•	•	•	•
	240 cm	•	•	•	•		•	•			•	•	•	•	•	•
	280 cm	•														
	300 cm		•	•							•	•	•	•	•	
400 cm		•														
500 cm																
600 cm																
Material	Ultra-white PVC															•
	Wmat-ST	•	•	•		•	•	•	•	•						
	Wmat-EL					•										
	Acoustic										•		•	•		•
Case	Color	White	White	White	Black	Black	White	White	Black	Black	Black	Black	Black	Black		Black
	Case structure	Alu	Alu	Alu	Alu	Alu	Steel	Steel	Alu	Steel	Alu	Alu	Alu	Alu		Alu
	Fixed bracket placement						•	•	•							
	Adjust. bracket placement	•	•	•	•											
Functions	Remote Control	•	•	•	•			•								
	Fine Adjustment System		•	•	•	•		•								
	Trigger		•	•	•											
	Sensor Extension for IR		•	•	•	•		•								
	Smooth Screen Rising (SSR)	•														
	Clipping System	•	•	•	•											
	Built-in AC Connector		•	•	•	•										
RS232		•	•	•												



SHOWPLACE PREMIUM

The Showplace screen is designed for installation in a false ceiling in order to disappear completely when not in use. Using the same ultra integrated control system of the Majestic and a Somfy motorization system, this screen offers the absolute best for prestige installations.

SCREEN MATERIAL

High quality Lumene screen material WMat-ST (1.0 gain, mat, black borders, black back...)

MOTOR

Somfy tubular motor, simple, reliable and quiet



CONTROL METHODS

RS232 for Home Automation
Built-in IR remote control system with fine adjustment system
Remote control included
Deported IR Sensor provided
12-Volt Trigger
Manual switch (Up, stop, down)



Available in 16:9 format: 200, 240, 300 cm models.



Motorized



Retractable



In-ceiling



Built-in IR remote control system



Fine adjustment system



Home automation



Motorized



Retractable



Built-in IR remote control system



Fine adjustment system



Home automation



Safe clipping system



Adjustable bracket placement



Wall, ceiling or suspended



MAJESTIC PREMIUM

The Majestic Premium is today's most complete motorized screen. Its top of the range screen material offers a perfect colorimetry and a large vision field. It includes an opaque black back, black borders and an extra-drop. The fast and safe attachment system allows an installation on wall, ceiling or suspended. Its control interface comprises an integrated infra red command (with a fine adjustment system for the screen material positioning and a deported sensor), trigger and RS232 inputs.

SCREEN MATERIAL

High quality Lumene screen material WMat-ST (1.0 gain, mat, black borders, black back...)

MOTOR

Somfy tubular motor, simple, reliable and quiet



CASE

White lacquered aluminum
Easy and fast install
Wall and ceiling mounting
Hook for hanging installation from ceiling

CONTROL METHODS

RS232 for Home Automation
Built-in IR remote control system with fine adjustment system
Remote control included
Deported IR Sensor provided
12-Volt Trigger
Manual switch (Up, stop, down)

Available in :

4:3 format: 200, 240, 300, 400 cm models.

16:9 format: 200, 240, 300 cm models.



COLISEUM PREMIUM

The Coliseum Premium is today's most complete tab-tensioned motorized screen. Its material offers a perfect colorimetry and a large vision field. It includes opaque black back, black borders, extra-drop and tab-tensioning. The fast and safe attachment system allows an installation on wall, ceiling or suspended. Its control interface comprises an integrated infra red command (with a fine adjustment system for the screen material positioning and a deported sensor), trigger and RS232 inputs.

SCREEN MATERIAL

High quality Lumene screen material WMat-EL (1.0 gain, mat, black borders, black back...)

MOTOR

Somfy tubular motor, simple, reliable and quiet



CONTROL METHODS

RS232 for Home Automation
Built-in IR remote control system with fine adjustment system
Remote control included
Deported IR Sensor provided
12-Volt Trigger
Manual switch (Up, stop, down)

CASE

Black lacquered aluminum
Easy and fast install
Wall and ceiling mounting
Hook for hanging installation from ceiling

Available in 16:9 format: 200, 240 cm models.



Motorized



Retractable



Tab tensioning system



Built-in IR remote control system



Home automation



Safe clipping system



Adjustable bracket placement



Wall, ceiling or suspended



Motorized



Retractable



Built-in IR remote control system



Easy to install



Wall, ceiling or suspended

EMBASSY 2

The Lumene screen called Embassy 2 has defined a new standard for middle range motorized screens. Very complete despite an attractive price, it benefits from a discreet and refined design. Home Cinema addicts will appreciate the finish quality (black borders, extra-drop, opaque black back, lacquered aluminum case) and the versatility (wall, ceiling or slot in a box thanks to a provided deported sensor).

SCREEN MATERIAL

High quality Lumene screen material WMat-ST (1.0 gain, mat, black borders, black back...)

MOTOR

Synchronous motor

CASE

White lacquered steel
Easy and fast install
Wall and ceiling mounting

CONTROL METHODS

Built-in IR remote control system
Remote control included
Deported IR Sensor provided
Manual switch (Up, stop, down)

Available in :

4:3 format: 170, 200, 240 cm models.

16:9 format: 200, 240 cm models.





MOVIE PALACE PREMIUM

Permanent screen with a high quality screen material, the Movie Palace Premium is the best choice for dedicated rooms. The best choice of screen for dedicated rooms.

The black frame, made of aluminum, maintains the tension of the fabric and ensures a perfectly flat surface. The large black velvet finish strengthens the image contrast and avoids undesirable reflection.



Fixed Frame Screen

FRAME

Large full aluminum alloy frame with velvet finish
Easy to assemble
Perfect tension for a long time flat viewing surface
Safe clipping system

SCREEN MATERIAL

High quality Lumene screen material : WMat-EL
Ultra white screen material
Permanent white treatment
1.0 gain
150° directivity
No hot spot
PVC material
Anti-static
Black back finish

Optional acoustically transparent screen (Acoustic)

Available in 16:9 format: 170, 200, 240, 300 cm models.



Easy to install



Perfect tension



Velvet Frame

MOVIE PALACE PREMIUM ACOUSTIC

The new Movie Palace Premium Acoustic offers a special acoustically transparent fabric (ACOUSTIC).

You can place the front speakers behind the screen and enjoy a true cinema experience.

ACOUSTIC CANVAS FOR PROJECTION SCREEN

The Lumene Acoustic screen material will allow you to place your speakers behind the fixed projection screen just like in real movie theaters. This screen is said to be acoustically transparent. When you replace the Movie Palace Premium

Specifications: same as Movie Palace Premium

Available in 16:9 format: 170, 200, 240, 300 cm models.



Fixed Frame Screen



Easy to install



Acoustically transparent



screen material by the Acoustic, you will create one of the best fixed screens of the market. Its exclusive technology ensures a perfect image, a neutral colorimetry as well as a real acoustical transparency.



Acoustically transparent

MOVIE PALACE PREMIUM CURVE

The Movie Palace Curve maintains the characteristics of the MoviePalace and adds a curved design that improves image clarity: the distance between the projector and the canvas is therefore identical (or much closer depending on the case) at the center of the image and along the outside borders. The ultra sturdy aluminum frame with velvet finish and the clip adherence system make this screen very simple to install and give it a very high production quality.



Fixed Frame Screen



Curved frame

FRAME

Curved full aluminum alloy frame with velvet finish
Easy to assemble
Perfect tension for a long time flat viewing surface
Safe clipping system

SCREEN MATERIAL

High quality Lumene screen material : WMat-EL
Ultra white screen material
Permanent white treatment
1.0 gain
150° directivity
No hot spot
PVC material
Anti-static
Black back finish

NEW 2011

Available in 16:9 format: 200, 240, 300 cm models.



Easy to install



Perfect tension



Velvet Frame

MOVIE PALACE PREMIUM MULTI

The screen for cinema lovers, it has a very wide range of possible uses. The Movie Palace Multi is suited equally well to high-end locations dedicated for projection (up to cinemascope 1:2.35 format) and to more "standard" settings like 16:9 or even 4:3.

Its lateral shutters are set in place in one move so you can adjust the film's projection surface (1:2.35, 16:9 or 4:3). Users who want to use the video projector for various types of events can select from a number of possible film formats, such as 16:9 and 4:3.



Fixed Frame Screen



Adjustable ratio

FRAME

Large full aluminum alloy frame with velvet finish
Lateral shutters to adjust film projection surface (1:2.35 - 16:9 - 4:3)
Easy to assemble
Perfect tension for a long time flat viewing surface
Safe clipping system

SCREEN MATERIAL

High quality Lumene screen material : WMat-EL
Ultra white screen material
Permanent white treatment
1.0 gain
150° directivity
No hot spot
PVC material
Anti-static
Black back finish

NEW 2011

Available in 1:2.35, 16:9, 4:3 formats: 200, 240, 300 cm models.



Easy to install



Perfect tension



Velvet Frame



With the Movie Palace Premium Curve, the bend conforms more accurately to our natural viewing focal length and thus creates an image for the viewer that is a near accurate match to the image.

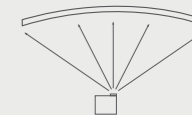

1:2.35 format



16:9 format



4:3 format



EDEN

The Eden is a motorized screen to be placed on the floor or on a piece of furniture. Ideal in situations where you cannot install the screen on the wall or on the ceiling. When the screen is hidden behind a piece of furniture or in a box, the integrated remote control system can be used with the provided external sensor. Its handle allows an easy transport and it can be deployed in a few minutes only. It comes with the same high level screen material as other Lumene screens.

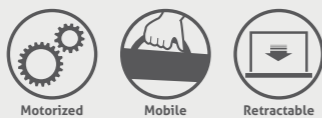

SCREEN MATERIAL

High quality Lumene screen material WMat-ST (1.0 gain, mat, black borders, black back...)

MOTOR

Quiet operating tubular motor

CONTROL METHODS

Built-in IR remote control system. Deported IR sensor provided. Remote control included. Manual switch (Up, stop, down)

CASE

Glossy black finish, Rust proof finish, Easy and fast install, To be installed on the floor or on a piece of furniture

Available in 16:9 format: 150, 180 cm models.

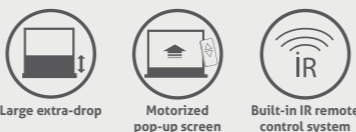

ARCADIA

Arcadia is a range of tripod standing projection screens with the same high quality screen material as Capitol range.

The Arcadia offers a versatile and efficient solution for all kind of presentations. The picture size can be easily set on the main aspect ratio: 1:1, 4:3 or 16:9.

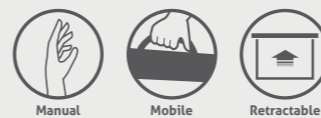

SCREEN MATERIAL

High quality Lumene screen material : WMat-ST (1.0 gain, mat, black border, black back...)

CASE

Black case on telescopic base Powder coated metal with rustproof finish Oversized spring for long time use Fast and easy to install

Available in
1:1 format: 150, 170 cm models.
4:3 format: 200 cm model.
16:9 format: 200 cm model.

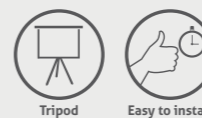

PARADISE

The Paradise is a portable screen ready in a few seconds: just pulling the fabric up, your screen is ready for use. Light weight and self-standing so it goes anywhere, the Paradise features a telescopic arm for raising and lowering the projection height. With a modern and uncluttered design, this screen has a high quality case made with slick aluminum finish.

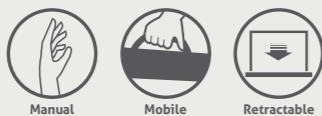

SCREEN MATERIAL

High quality Lumene screen material : WMat-ST (1.0 gain, mat, black border, black back...)

CASE

Black case with telescopic system Aluminum alloy casting Oversized spring for long time use Fast and easy to install

Available in
4:3 format: 130, 170 cm models.
16:9 format: 130, 170 cm models.

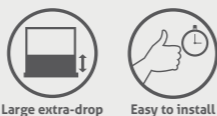

TABLESHOW

Portable screen for table presentation. Extremely compact and very light, the Lumene TableShow screen, combined with your pico-projector, will allow you to make very professional presentations in the wink of an eye.

Thanks to its very efficient and user friendly design, you will be able to pull your screen up and down in a few seconds only. As all other Lumene screens, the TableShow is equipped with an ultra-white projection fabric with a large viewing angle (essential for an off-axis vision) and with black borders to improve contrast. The aluminum case combines lightness and rigidity for a very smooth utilization. The patented arms system at the back will ensure the fabric tension.

SCREEN MATERIAL

High quality Lumene screen material : WMat-ST (1.0 gain, mat, black border, black back...)

CASE

Black case with telescopic system Aluminum alloy casting Oversized spring for long time use Fast and easy to install

Available in 4:3 format: 65, 80, 102, 126 cm models.

NEW 2011





CAPITOL PREMIUM

The Capitol Premium is today's best manual screen. To roll it up, just release it and the whole screen will rise very smoothly thanks to its advanced technology called SSR*. The high level screen material has an opaque black back, black borders and an extra-drop. The fast and safe clipping system will allow wall, ceiling and even suspended mounting.

SCREEN MATERIAL

High quality Lumene screen material WMat-ST (1.0 gain, mat, black borders, black back...)

CASE

White lacquered aluminum Automatic locking system, simple and efficient *Smooth screen rising Oversized spring for long time use Easy and fast install Wall and ceiling mounting Hook for hanging installation from ceiling

Available in
4:3 format: 200, 240, 280 cm models.
16:9 format: 200, 240, 280 cm models.



Manual



Retractable



Smooth screen rising



Wall, ceiling or suspended



Automatic locking system



Safe clipping system



Adjustable bracket placement



PLAZZA 2

An affordable manual screen with a refined finish. The second generation of the Plaza screens offers an unequalled finish at that price level: high performances material with black borders, opaque black back, extra-drop. The case is in lacquered steel with an elegant design. It can be simply mounted on the wall or the ceiling and even slot in a box. Moreover, it utilizes an automatic locking system allowing an easy and useful adjustment to the dimensions wished for projection.

SCREEN MATERIAL

High quality Lumene screen material WMat-ST (1.0 gain, mat, black borders, black back...)

CASE

White lacquered steel Slim case for an installation in reduced places Oversized spring to lengthen the screen life Automatic locking system, simple and efficient Easy and fast install Wall and ceiling mounting

Available in
4:3 format: 150, 170, 200, 240 cm models.
16:9 format: 200, 240 cm models.



Manual



Retractable



Easy to install



Wall, ceiling or suspended



Automatic locking system

WIRELESS SCREEN TRIGGER

This accessory lets users initiate screen opening once the projector comes on. This wireless trigger gives you very simple installation with no hidden cables in the ceiling.



Easy to install

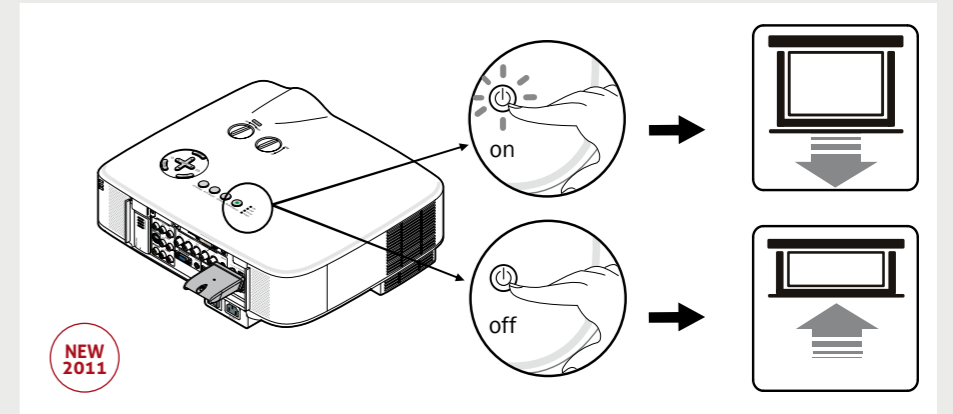

CEILING PROJECTOR MOUNT

The Lumene videoprojector ceiling mount give you easy placement in the most discreet setting possible. You can orient and incline according to several axes. The model features cable-masks, height adjustment, and easy settings adjustment once the projector is in place. The articulated and telescopic arms adapt to all projector models. This model offers the Kensington® anti-theft plug security feature.



Easy to install

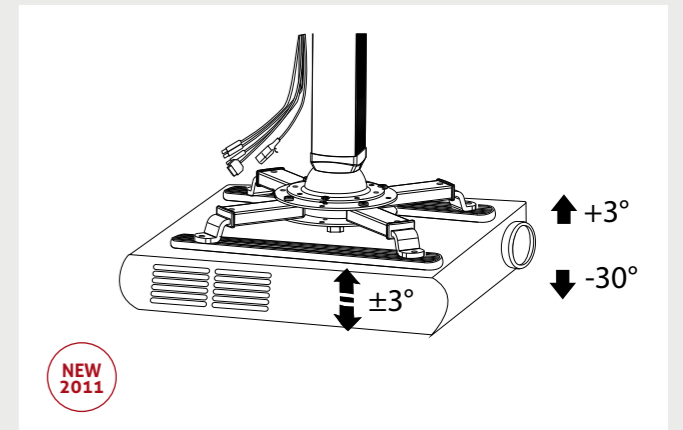

SCREENS SPECIFICATIONS

MOTORIZED SCREENS

SHOWPLACE PREMIUM

	Ratio	Diagonal (cm/inch)	Image Area (cm/inch)		Black Drop (cm/inch)			Fabric Size (cm/inch)		Case with brackets (cm/inch)			Net Weight kg/lbs	Gross Weight kg/lbs	Packaging Size (cm/inch)		
			W	H	side	bottom	top	W	H	W	H	D			W	H	D
ShowPlace Premium 200C	16/9	234	204	115	5	5	65	214	185	246	17	16	27,0	30,5	253	27	23
		92	80,2	45,1	2	2,0	25,6	84,1	72,7	96,9	6,7	6,3	59,5	67,2	99	10,4	9,1
ShowPlace Premium 240C	16/9	269	235	132	5	5	50	245	187	277	17	16	29,2	33,0	284	27	23
		106	92,4	52,0	2	2,0	19,7	96,3	74	109,1	6,7	6,3	64,4	72,8	112	10,4	9,1
ShowPlace Premium 300C	16/9	350	306	172	5	5	40	316	217	348	17	16	32,0	37,2	354	27	23
		138	120,3	67,6	2	2,0	15,7	124,2	85,4	137,2	6,7	6,3	70,5	82,0	139,3	10,4	9,1

COLISEUM PREMIUM

	Ratio	Diagonal (cm/inch)	Image Area (cm/inch)		Black Drop (cm/inch)			Fabric Size (cm/inch)		Case with brackets (cm/inch)			Net Weight kg/lbs	Gross Weight kg/lbs	Packaging Size (cm/inch)		
			W	H	side	bottom	top	W	H	W	H	D			W	H	D
Coliseum Premium 200C	16/9	233	203	115	10	6	40	223	160	252	18	16	19,6	24,9	212	21	21
		92	79,9	45,1	3,9	2,2	15,7	87,8	63	99,2	7,1	6,3	43,2	54,9	83,5	8,3	8,3
Coliseum Premium 240C	16/9	269	234	132	10	6	40	254	178	283	18	16	22,5	27,9	323	21	21
		106	92,1	52	3,9	2,2	15,7	100	69,9	111,6	7,1	6,3	49,6	61,5	127,3	8,3	8,3

EMBASSY 2

	Ratio	Diagonal (cm/inch)	Image Area (cm/inch)		Black Drop (cm/inch)			Fabric Size (cm/inch)		Case with brackets (cm/inch)			Net Weight kg/lbs	Gross Weight kg/lbs	Packaging Size (cm/inch)		
			W	H	side	bottom	top	W	H	W	H	D			W	H	D
Embassy 2 170 V	4/3	214	171	128	5	6	7	181	205	209	9	9	11,3	13	237	13	17
		84	67,3	50,4	2	2,2	2,8	71,3	80,7	82,2	3,6	3,4	24,9	28,7	93,1	5	6,5
Embassy 2 200 V	4/3	254	203	152	5	6	7	213	165	240	9	9	12,3	14,1	267	13	17
		100	79,9	59,8	2	2,2	2,8	83,9	64,8	94,3	3,6	3,4	27,1	31,1	104,9	5	6,5
Embassy 2 200 C	16/9	233	203	115	5	6	40	213	160	240	9	9	12,3	14,1	267	13	17
		92	79,9	45,1	2,0	2,2	15,7	83,9	63	94,3	3,6	3,4	27,1	31,1	104,9	5	6,5
Embassy 2 240 V	4/3	292	234	176	5	6	7	244	188	270	9	9	15,5	17,6	297	13	17
		115	92	69,1	2	2,2	2,8	96	74	106,3	3,6	3,4	34,2	38,8	117	5	6,5
Embassy 2 240 C	16/9	269	234	132	5	6	50	243	188	270	9	9	15,5	17,6	297	13	17
		106	92,1	52	1,9	2,2	19,7	95,8	73,8	106,3	3,6	3,4	34,2	38,8	117	5	6,5

MAJESTIC PREMIUM

	Ratio	Diagonal (cm/inch)	Image Area (cm/inch)		Black Drop (cm/inch)			Fabric Size (cm/inch)		Case with brackets (cm/inch)			Net Weight kg/lbs	Gross Weight kg/lbs	Packaging Size (cm/inch)		
			W	H	side	bottom	top	W	H	W	H	D			W	H	D
Majestic Premium 200V	4/3	254	203	152	5	6	8	213	166	228	12	11	12,4	15,2	259	16	15
		100	79,9	59,8	2	2,2	3,1	83,9	65,2	89,7	4,6	4,4	27,3	33,5	102	6,4	5,9
Majestic Premium 200C	16/9	233	203	115	5	6	40	213	160	227	12	11	12,4	15,2	259	16	15
		92	79,9	45,1	2	2,2	15,7	83,9	63	89,4	4,6	4,4	27,3	33,5	102	6,4	5,9
Majestic Premium 240V	4/3	300	240	180	5	6	8	250	194	265	12	11	14,3	17,3	296	16	15
		118	94,5	70,9	2	2,2	3,1	98,4	76,2	104,3	4,6	4,4	31,5	38,1	116,6	6,4	5,9
Majestic Premium 240C	16/9	269	234	132	5	6	50	244	188	258	12	11	14,1	17	290	16	15
		106	92,1	52	2	2,2	19,7	96,1	73,8	101,7	4,6	4,4	31,1	37,5	114	6,4	5,9
Majestic Premium 300V	4/3	381	305	229	5	8	8	315	245	335	18	16	29,4	33,5	375	21	21
		150	120,0	90	2	3,1	3,1	123,9	96,3	131,8	7,1	6,3	64,8	73,9	147,6	8,3	8,3
Majestic Premium 300C	16/9	350	305	172	5	8	30	315	210	335	18	16	29,4	33,5	375	21	21
		138	120,0	67,5	2	3,1	11,8	123,9	82,5	131,8	7,1	6,3	64,8	73,9	147,6	8,3	8,3
Majestic Premium 400V	4/3	503	402	302	5	8	8	412	318	432	18	16	49	58	472	21	21
		198	158,3	118,7	2	3,1	3,1	162,2	125	170	7,1	6,3	108	127,9	185,7	8,3	8,3

FIXED FRAME SCREENS

MOVIE PALACE PREMIUM

	Ratio	Diagonal (cm/inch)	Image Area (cm/inch)		Black Frame (cm/inch)			Frame Size (cm/inch)			Net Weight kg/lbs	Gross Weight kg/lbs	Packaging Size (cm/inch)		
			W	H	side	bottom	top	W	H	D			W	H	D
Movie Palace Premium 170C	16:9	196	171	96	8	8	8	187	112	4,8	9,1	15,5	199,5	23,5	16
		77	67,3	37,8	3,1	3,1	3,1	73,6	44,1	1,9	20,1	34,2	78,5	9,3	6,3
Movie Palace Premium 200C	16:9	233	203	114,5	8	8	8	219	130,5	4,8	11,0	18,1	233	23,5	16
		92	79,9	45,1	3,1	3,1	3,1	86,2	51,4	1,9	24,3	39,9	91,7	9,3	6,3
Movie Palace Premium 240C	16:9	269	234	132	8	8	8	250	148	4,8	12,8	21,2	264	23,5	16
		106	92,1	52	3,1	3,1	3,1	98,4	58,3	1,9	28,2	46,7	103,9	9,3	6,3
Movie Palace Premium 300C	16:9	350	304,8	171,5	8	8	8	320,8	187,5	4,8	16,5	25,5	335,5	23,5	16
		138	120	67,5	3,1	3,1	3,1	126,3	73,8	1,9	36,4	56,2	132,1	9,3	6,3

MOVIE PALACE PREMIUM CURVE

	Ratio	Diagonal (cm/inch)	Image Area (cm/inch)		Black Frame (cm/inch)			Frame Size (cm/inch)			Net Weight kg/lbs	Gross Weight kg/lbs	Packaging Size (cm/inch)		
			W	H	side	bottom	top	W	H	D			W	H	D
Movie Palace Premium Curve 200C	16:9	234	204	114,5	8	8	8	219,7	130,5	6	11,3	17,9	217,3	33	13
		92	80,2	45,1	3,1	3,1	3,1	86,5	51,4	2,4	24,9	39,5	85,6	13,0	5,1
Movie Palace Premium Curve 240C	16:9	269	235	132	8	8	8	250,6	147,9	6	12,7	19,5	248,5	33	13
		106	92,4	52	3,1	3,1	3,1	98,7	58,2	2,4	28,0	43,0	97,8	13,0	5,1
Movie Palace Premium Curve 300C	16:9	350	305	172	8	8	8	320,8	187,5	6	16,5	23,5	318,8	33	13
		138	120	67,5	3,1	3,1	3,1	126,3	73,8	2,4	36,4	51,8	125,5	13,0	5,1

MOVIE PALACE PREMIUM MULTI

	Ratio	Diagonal (cm/inch)	Image Area* (cm/inch)		Black Frame (cm/inch)			Frame Size (cm/inch)			Net Weight kg/lbs	Gross Weight kg/lbs	Packaging Size (cm/inch)		
			W	H	side	bottom	top	W	H	D			W	H	D
*Image area is for 1:2,35 ratio															
Movie Palace Premium Multi 200C	2.35:1 16:9 4:3	234	215	91,5	variable	10,5	10,5	245	112,5	10,8	11,3	17,9	217,3	33	13
		92	84,6	36,0		4,1	4,1	96,5	44,3	4,3	24,9	39,5	85,6	13,0	5,1
Movie Palace Premium Multi 240C	2.35:1 16:9 4:3	269	248	105	variable	10,5	10,5	278	126,4	10,8	12,7	19,5	248,5	33	13
		106	97,5	41		4,1	4,1	109,3	49,8	4,3	28,0	43,0	97,8	13,0	5,1
Movie Palace Premium Multi 300C	2.35:1 16:9 4:3	335	309	131	variable	10,5	10,5	339	152,3	10,7	16,5	23,5	318,8	33	13
		132	121	51,7		4,1	4,1	133,3	60,0	4,2	36,4	51,8	125,5	13,0	5,1

MOBILE SCREENS

EDEN

	Ratio	Diagonal (cm/inch)	Image Area (cm/inch)		Black Drop (cm/inch)			Fabric Size (cm/inch)		Case with brackets (cm/inch)			Net Weight kg/lbs	Gross Weight kg/lbs	Packaging Size (cm/inch)		
			W	H	side	bottom	top	W	H	W	H	D			W	H	D
Eden 150 C	16/9	178	155	87	4	70	-	162	157	172	11	26	19,3	21,2	197	20	37
		70	61	34,3	1,4	27,6	-	63,8	61,9	67,7	4,1	10,2	42,5	46,7	77,4	7,9	14,6
Eden 180 C	16/9	203	177	100	4	80	-	184	180	194	11	26	21,5	23,5	219	20	37
		80	69,7	39,2	1,4	31,5	-	72,4	70,7	76,3	4,1	10,2	47,4	51,8	86,2	7,9	14,6

PARADISE

	Ratio	Diagonal (cm/inch)	Image Area (cm/inch)		Black Drop (cm/inch)			Fabric Size (cm/inch)		Case with brackets (cm/inch)			Net Weight kg/lbs	Gross Weight kg/lbs	Packaging Size (cm/inch)		
			W	H	side	bottom	top	W	H	W	H	D			W	H	D
Paradise 130V	4/3	152	122	91,4	3,5	2,5	69,5	129	163,4	138	14,5	10,5	4,8	6,2	148	18,3	15
		60	48	36	1,4	1	27,4	50,8	64,3	54,3	5,7	4,1	10,6	13,7	58,3	7,2	5,9
Paradise 130C	16/9	152	132,8	74,7	3,5	2,5	73,8	139,8	151	148,8	14,5	10,5	5,4	6,8	158,8	18,3	15
		60	52,3	29,4	1,4	1	29,1	55,0	59,4	58,6	5,7	4,1	11,8	15	62,5	7,2	5,9
Paradise 170V	4/3	203	162,5	122	3,5	2,5	70	169,5	194,5	179,5	14,5	10,5	6,2	8,0	188,5	18,3	15
		80	64	48	1,4	1	27,6	66,7	76,6	70,7	5,7	4,1	13,7	17,6	74,2	7,2	5,9
Paradise 170C	16/9	203	177	99,5	2,8	2,5	101,8	182,6	203,8	191,6	14,5	10,5	6,7	8,7	203	18,3	15
		80	69,7	39,2	1,1	1	40,1	71,9	80,2	75,4	5,7	4,1	14,8	19,2	79,9	7,2	5,9

ARCADIA

	Ratio	Diagonal (cm/inch)	Image Area (cm/inch)		Black Drop (cm/inch)			Fabric Size (cm/inch)		Case with brackets (cm/inch)			Net Weight kg/lbs	Gross Weight kg/lbs	Packaging Size (cm/inch)		
			W	H	side	bottom	top	W	H	W	H	D			W	H	D
Arcadia 150	1/1	215	152	152	3	-	-	158	152	176,5	10	18,2	7,8	9,5	191	12	20
		85	59,8	59,8	1,2	-	-	62,2	59,8	69,5	3,9	7,2	17,2	20,9	75,2	4,7	7,9
Arcadia 170	1/1	243	172	172	3	-	-	178	172	196,5	10	18,2	8,9	10,7	211	12	20
		96	67,7	67,7	1,2	-	-	70,1	67,7	77,4	3,9	7,2	19,6	23,6	83,1	4,7	7,9
Arcadia 200V	4/3	254	203	152	4	-	-	211	152	229	10	18,2	9,5	12	244	12	20
		100	79,9	59,8	1,6	-	-	83,1	59,8	90,2	3,9	7,2	20,9	26,5	96,1	4,7	7,9
Arcadia 200C	16/9	233	203	115	4	-	-	211	152	229	10	18,2	9,3	11,8	244	12	20
		92	79,9	45,1	1,6	-	-	83,1	59,8	90,2	3,9	7,2	20,5	26	96,1	4,7	7,9

TABLESHOW

	Ratio	Diagonal (cm/inch)	Image Area (cm/inch)		Black Drop (cm/inch)			Fabric Size (cm/inch)		Case with brackets (cm/inch)			Net Weight kg/lbs	Gross Weight kg/lbs	Packaging Size (cm/inch)		
			W	H	side	bottom	top	W	H	W	H	D			W	H	D
TableShow 65	4/3	81	65	49	3,5	2	2	67	52	74	4	6	1,0	1,5	81	8	9
		32	26	19	1,4	1	0,8	26,4	20,5	29,1	1,6	2,4	2,2	3,3	31,9	3,1	3,5
TableShow 80	4/3	101	81	61	3,5	2	2	85	67	91	4	6	1,3	1,7	96	8	9
		40	31,9	24,0	1,4	1	0,8	33,5	26,4	35,8	1,6	2,4	2,9	4	37,8	3,1	3,5
TableShow 102	4/3	127	101,6	76,2	2,5	2	2	106,6	80,2	112,4	8,4	5,5	2,8	3,6	121,5	11,5	14
		50	40	30	1,0	1	0,8	42,0	31,6	44,3	3,3	2,2	6,2	7,9	47,8	4,5	5,5
TableShow 126	4/3	147	121,9	81,4	2,5	2	2	125,9	86,9	132,7	8,4	5,5	3,3	4,3	141,5	11,5	14
		58	48,0	32,0	1,0	1	0,8	49,6	34,2	52,2	3,3	2,2	7,2	9,5	55,7	4,5	5,5

MANUAL SCREENS

PLAZZA 2

	Ratio	Diagonal (cm/inch)	Image Area (cm/inch)		Black Drop (cm/inch)			Fabric Size (cm/inch)		Case with brackets (cm/inch)			Net Weight kg/lbs	Gross Weight kg/lbs	Packaging Size (cm/inch)		
			W	H	side	bottom	top	W	H	W	H	D			W	H	D
Plazza 2 150 V	4/3	183	146	110	3	3	8	151	121	163	9	9	7,0	8,8	177	13	17
		72	57,5	43,3	1	1,2	3,1	59,4	47,6	64,2	3,6	3,4	15,4	19,4	69,7	5	6,5
Plazza 2 170 V	4/3	214	171	128	4	3	8	179	139	191	9	9	8,2	10,2	205	13	17
		84	67,3	50,4	1,6	1,2	3,1	70,5	54,7	75,2	3,6	3,4	18,1	22,4	80,6	5	6,5
Plazza 2 200 V	4/3	254	203	152	5	6	8	213	166	225	9	9	10,6	12,4	239	13	17
		100	79,9	59,8	2	2,4	3,1	83,9	65,4	88,6	3,6	3,4	23,4	27,3	94,1	5	6,5
Plazza 2 200 C	16/9	233	203	115	5	6	40	213	161	225	9	9	10,6	12,4	239	13	17
		92	79,9	45,1	2	2,4	15,7	83,9	63,2	88,6	3,6	3,4	23,4	27,3	94,1	5	6,5
Plazza 2 240 V	4/3	293	234	176	5	5	8	243	188	255	9	9	13,3	15,2	270	13	17
		115	92,1	69,1	1,9	1,8	3,1	95,8	74	100,6	3,6	3,4	29,3	33,4	106,3	5	6,5
Plazza 2 240 C	16/9	269	234	132	5	5	50	243	187	255	9	9	13,3	15,2	270	13	17
		106	92,1	52	1,9	1,8	19,7	95,8	73,4	100,6	3,6	3,4	29,3	33,4	106,3	5	6,5

CAPITOL PREMIUM

	Ratio	Diagonal (cm/inch)	Image Area (cm/inch)		Black Drop (cm/inch)			Fabric Size (cm/inch)		Case with brackets (cm/inch)			Net Weight kg/lbs	Gross Weight kg/lbs	Packaging Size (cm/inch)		
			W	H	side	bottom	top	W	H	W	H	D			W	H	D
Capitol Premium 200V	4/3	254	203	152	5	6	8	213	166	220	10	10	10,2	12,5	240	15	14
		100	79,9	59,8	2	2,4	3,1	83,9	65,4	86,8	3,9	3,9	22,5	27,6	94,3	5,9	5,6
Capitol Premium 200C	16/9	233	203	115	5	6	40	213	161	220	10	10	10,2	12,5	240	15	14
		92	79,9	45,1	2	2,4	15,7	83,9	63,2	86,8	3,9	3,9	22,5	27,6	94,3	5,9	5,6
Capitol Premium 240V	4/3	293	234	176	4,7	5	8	243	188	251	12	11	13,9	16,8	277	16	15
		115	92,1	69,1	1,9	1,8	3,1	95,8	74	98,8	4,6	4,4	30,5	37	109,1	6,4	5,9
Capitol Premium 240C	16/9	269	234	132	4,7	5	50	243	187	251	12	11	13,9	16,8	277	16	15
		106	92,1	52	1,9	1,8	19,7	95,8	73,4	98,8	4,6	4,4	30,5	37	109,1	6,4	5,9
Capitol Premium 280V	4/3	352	282	211	5	5	8	292	224	299	12	11	18,2	22,5	325	16	15
		139	110,9	83,1	2	1,8	3,1	114,8	88,1	117,8	4,6	4,4	40,1	49,6	128,1	6,4	5,9
Capitol Premium 280C	16/9	323	282	159	5	5	30	292	193	299	12	11	18,2	22,5	325	16	15
		127	110,9	62,4	2	1,8	11,8	114,8	76	117,8	4,6	4,4	40,1	49,6	128,1	6,4	5,9



Edition: 2011/01

Lumene is a registered trademark of INOVADIS - France - RCS Créteil B 452 455 983

www.lumene-screens.com